

FOURTEENTH-CENTURY HALLS IN THE EAST WEALD

By S. E. RIGOLD, F.S.A.

THE excavation at Pivington of the complete ground-wall plan of an early fourteenth-century timber-framed house, replaced in the early sixteenth by one apparently of the common unitary-roofed hall type,¹ only emphasizes the fact that halls of the fifteenth and early sixteenth centuries survive in Kent in their thousands, while known timber halls earlier than, say, 1370 can be counted on the fingers. Identified early halls are relatively much more numerous in Essex and Suffolk,² while Mr. R. T. Mason has published a number of examples from the Sussex and Surrey Weald.³ That such halls were all but exterminated in Kent by a great late medieval rebuilding, perhaps to be associated with a radical change in local agriculture, seems inescapable. Nevertheless, it was to be hoped that a few might have yet escaped even to this day.

When the writer was working at Pivington he searched the immediate vicinity. At Rooting in Pluckley he noticed an obvious, independently roofed, low-end cross-wing, distinguished by a massive and striking form of external framing. When he was permitted to examine the house it proved in some ways disappointing, the adjoining hall-block having been completely rebuilt. However, in view of the unusual details of the wing, which point to the second half of the fourteenth century, a description is included here.

More recently, at Hamden in Smarden, he noticed a house of which the only visible early detail was in the projecting porch, but the breadth and low side-walls of the hall suggested that it was aisled. Internally this house proved to be beyond all expectations and the writer expresses his gratitude to the Misses Millen for their interest and helpfulness once the extraordinary significance of their house had been pointed out. It has a 'base-cruck' hall with two notional aisles, and much of the original cross-wing is intact inside a later building. The characteristic and splendid truss spanning the hall is complete

¹ *Arch. Cant.*, lxxvii (1962), 27-47.

² Cf. the heavy concentration of aisled halls in this area on fig. 13, 133, of J. T. Smith, 'Medieval Roofs', *Arch. J.*, cxv (1958), 110-49; there have been many subsequent discoveries.

³ 'Fourteenth-century Halls in Sussex', *Sussex Arch. Coll.*, xcv (1957), 71-93, and 'Chennells Brook Farm, Horsham', *ibid.*, ci (1963), 40-47, summarized in Mr. Mason's *Framed Buildings of the Weald*, 16-25; for an even earlier instance, with parallels, R. T. Mason, 'Old Court Cottage, Limpfield', *Surrey Arch. Coll.*, lxxiii (1966), 130-37.

FOURTEENTH-CENTURY HALLS IN THE EAST WEALD

apart from its feet and analogous in construction with several of Mr. Mason's Sussex examples,⁴ but lighter and more delicate in carpentry and with early fourteenth-century detail of first quality, probably from the second quarter of the century. It is not necessary to regard it as a stray from Sussex; but rather as a survivor of a once common species of which the lost hall at Rooting may have been one. The 'base-cruck', a neat refinement on aisled construction, for which we now have a fairly continuous distribution from Shropshire to Kent,⁵ no instance of which need be earlier than the middle of the thirteenth century, is indeed known in Kent but in all but two cases they are at first-floor level.⁶ Apart from Pivington, which was probably too short to need a central truss, excavation at Joyden's Wood has shown a wide hall, probably with a unitary roof, that most likely had 'base-crucks'.⁷ If the overall roof is dominant in Kent, the independent low-end cross-wing, found at Hamden and Rooting, and recessive but never extinct here, remained more typical of East Anglia than of Sussex and Wessex, and the relatively light scantling of Hamden has likewise more affinities with the East.⁸

The tenements of Rooting and Hamden were wealthier than the average (more or less) free holding on which the typical late medieval halls are so commonly found and it is likely that the predecessors of such halls were replaced (compare Pivington) simply because they were too small for the rising status of late medieval yeoman. Rooting was already held by St. Augustine's in Domesday Book and thereafter reckoned a manor (not that that meant much in the Weald). It was too distant to serve as a demesne and by 1365-66 a family of tenants in free socage had been established long enough to take their surname

⁴ See Note 3; mechanically, the exact parallels are Chennells Brook and Homewood House, Bolney.

⁵ The map in Mason, *Framed Buildings of the Weald*, fig. 5, p. 23, is the latest available but very incomplete—at least nine examples in Wilts., northern Hants, Berks., Bucks. and Middlesex help to fill in the gap between the two apparently isolated groups.

⁶ There was a ground-level base-cruck in a barn at Wrotham—*Arch. Cant.*, lxxxi (1966), 22 and fig. 3, 13. The base-crucked upper chambers are widely scattered: Benover, near Yalding; Ightham Mote (outer court); Kennington; Etchinghill; Frogholt, Newington-next-Hythe; Stockbury.

⁷ *Arch. Cant.*, lxxii (1958), 18-39. The ground-walls were substantially reinforced at the position of the central truss; there were certainly no aisle-posts and the very width of the hall precludes a full cruck but is perfectly consistent with a base-cruck. The construction was probably shortly before 1300.

⁸ The contemporary cross-wing at Chennells Brook is a *high-end* chamber-block, so is the later cross-wing at Tickerage, West Hoathly; this arrangement, found as early as Salisbury Old Deanery, is exceptional but rather less so in Wessex—in Kent, cf. Southfleet Old Rectory. In the east country the only cross-wing, or the earlier of two, is almost invariably at the *low end* (cf. among aisled halls, Little Chesterford, Kingston Old Rectory, Cambridge). For the relatively light scantling again cf. Little Chesterford.

from it.⁹ Afterwards it passed to larger local landholders, the St. Legers and in 1570 the Derings—it lies just outside the present Surrenden park. The quality of the building cannot be explained by ascribing it to craftsmen in the regular employ of the Abbey, but rather to the fact that the late fourteenth-century tenants required a grander house than their neighbours, and that it escaped complete rebuilding because it ceased to be an independent family holding. Hamden was originally indistinguishable from the other surrounding dens,¹⁰ but by 1361 one John Hamden was rich enough to leave the oldest recorded perpetual endowment of Smarden parish, yielding the then respectable sum of 6s. 0d. *per annum*.¹¹ In point of date, he or his father may well have been the builder of the present house and likewise a pioneer of the forest reclamation that progressively transformed these small clearings into intensive farms, with small fields, each with their pond, that are so characteristic of the district. West of the house are rectangular ponds suggesting stews, or possibly an incomplete moat; south-west of the house is a two-storey, post-medieval granary.

HAMDEN (TQ891407)

The house (Plate IA, Fig. 1 upper) is now completely and harmoniously cased in brick at the front and sides and in stone at the rear and presents a hip-roofed hall-block, with low walls, and a two-storied end-block, two bays wide, with brick-mullioned windows and also hip-roofed; the porch indicates the screens passage. The façade and the front hip of the end-block apparently date from 1839; this date and the initials R.D.¹² are carved on the dentilled cornice made up of two different pieces of fascia, framed between the ends of two pairs of lateral plates, which were tapered to carry barge-boards and show that the block is composed of two parallel ranges, both formerly jettied and gabled—the early cross-wing (C) against the hall and a seventeenth-century addition (D). A double chimney-stack in the former screens-passage serves both the hall and the wing, where a parlour has replaced the original service-rooms; an external stack serves the added range. In the plan, Fig. 1, secondary features are shown in dotted lines.

Preservation of the original Structure. In simplest terms, the roof of

⁹ Hasted, quarto ed., vii, 472.

¹⁰ Most of those in Smarden owed light dues to Christ Church or the archbishop, who also usurped rights at Rooting (Furley, *Hist. Weald of Kent*, ii, 134).

¹¹ Hasted, quarto ed., vii, 482. The endowment was a charge on the land at Hamden, still recognized by the present holders; at least after the Reformation it was assigned to bell-ropes. F. F. Haslewood, *Memorials of Smarden*, 229, gives the date of John's death as 1371. A John Hamden was involved in an affray at Wye temp. Edward I; Furley, *op. cit.*, ii, 244.

¹² Presumably the tenant; according to Hasted the estate passed to the Turners (late seventeenth century) and the Tokes of Godinton (late eighteenth century).



A. Hamden, Exterior from S.

S.E.R.



B. Hamden, Outer Door of Porch.

S.E.R.

PLATE II



A. Hamden, Base-Cruck Truss, S. Half.

S.E.R.



B. Rooting, Exterior from E.

S.E.R.

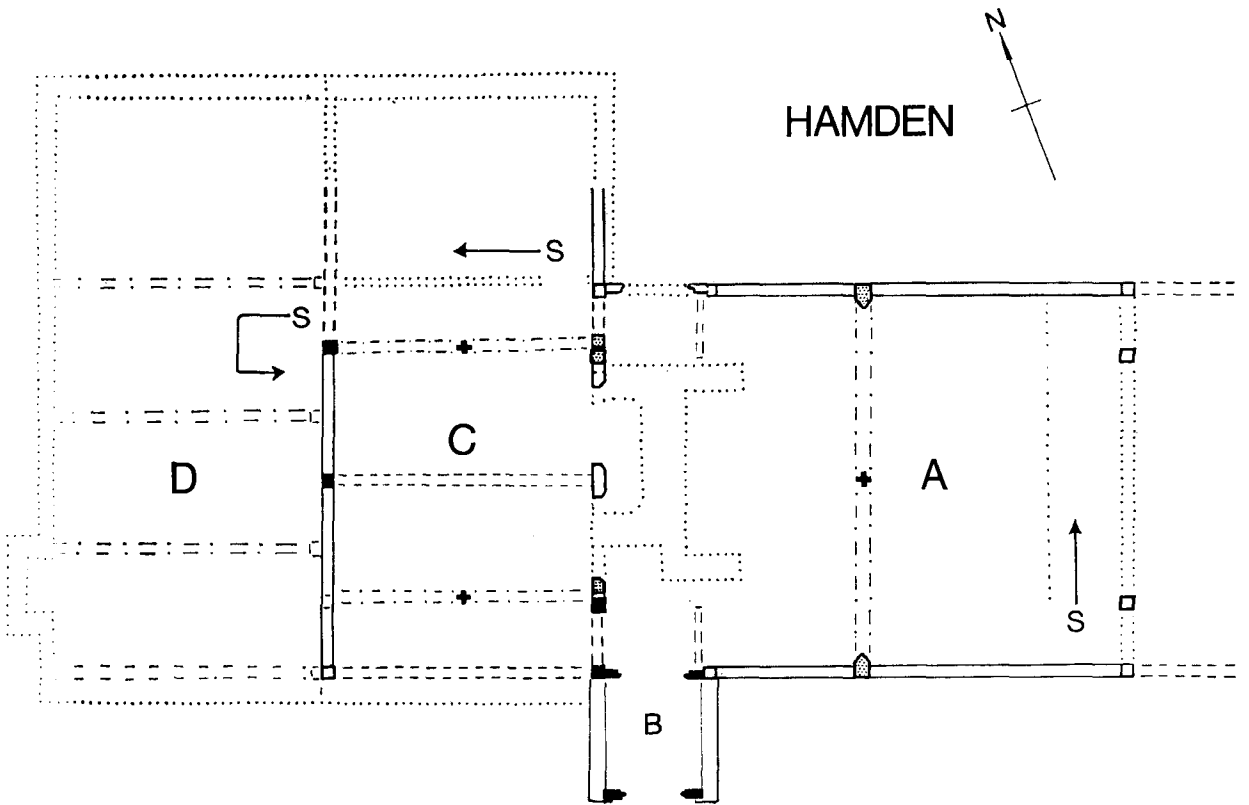
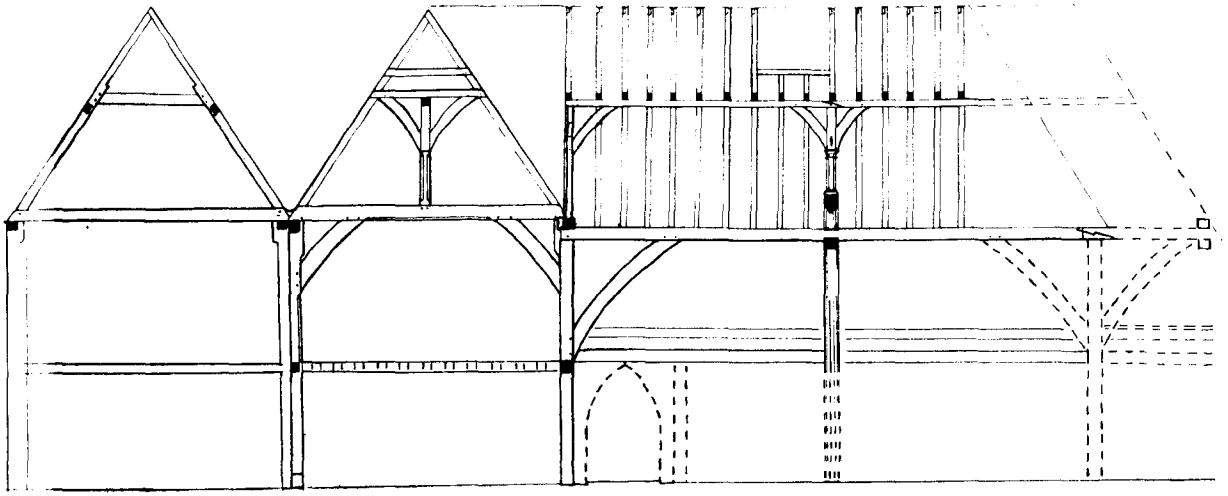

Original Posts:

- To ground
- ▣ Feet cut
- Removed

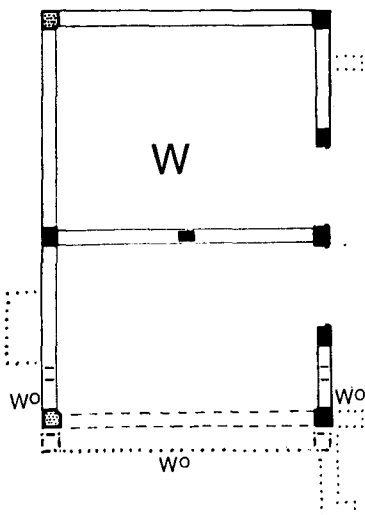

Walls:

- Approx. on original lines
- - - Restored " " "
- ⋯ Later
- - - Trusses + Crown posts
- S → Later stairs up
- Wo Window over

SITE OF
HALL



ROOTING

FIG. 1.

FOURTEENTH-CENTURY HALLS IN THE EAST WEALD

the hall was carried on two longitudinal (main, or arcade) plates, the ends of which rested on four posts, inset from the corners by the width of the 'quasi-aisles', and probably standing, as at Pivington¹³ on separate padstones. The plates were linked by tie-beams at either end and in the centre, but the central tie rested not over vertical posts but over the ends of bent principal posts ('base-crucks'), rising from the outer walls of the hall (compare Fig. 2, A and B).

Apart from the front door-case and one inset post, in the partition with the cross-wing, no timber-work of the hall survives below head-room level and little is visible in the ground floor of the wing. Above that level the frame is virtually complete. The one intact inset post (see Fig. 1) just within the door, carries a perfect, square-sectioned arch-brace, rising in vertical plane to the main plate. A glimpse of this post and the springing of the brace was enough to show the true nature of the hall. The posts and braces at the other end have been removed but their seatings are perfectly clear on the undersides of the main plates, which are magnificent and flawless timbers, about 9 in. square, spanning the whole surviving length (32 ft.) of the hall, without a join.¹⁴ The hall is divided into two nearly equal bays by the base-cruck truss, of which the feet are cut off just below the present ground-floor ceiling of the hall, but which is absolutely intact from there upwards. Above the mortices for the 'high-end' posts, at the extremity of the present building, the main plates have a 'splayed and tabled' scarf,¹⁵ which can only mean that the hall-block continued in series for at least half a bay. This was probably a 'cantilevered half-bay', as in aisled barns¹⁶ and the hip would have carried past the lost 'cantilevered tie' (or perhaps a pair of them),¹⁷ to a low end-wall level with the side-walls. This extra space, as at Nurstead¹⁸ probably contained a lofted inner chamber; at Purton Green, Suffolk,¹⁹ where there is a scarf in a similar position, the 'low end' apparently had a similar treatment. This is provisionally restored in the longitudinal section (Fig. 1) where the details of the posts and braces are also supplied from the intact instance opposite. The early wing, though functionally

¹³ See note 1, p. 246. There are other examples of inset posts in Kent that need comparative study, e.g. Fairfield Cottages, Eastry; Sole Street Cottages, Crundale.

¹⁴ At Chennells Brook one corresponding member runs for 40 ft. before a scarf is needed—a fantastic length when oak tie-beams seldom exceed 21 or 22 ft.

¹⁵ For definition see *Arch. Cant.*, lxxxi (1966), 3 and fig. 1, B and C. As at Chennell's Brook it has face-pegs only, no 'keys'.

¹⁶ *Ibid.*, 7.

¹⁷ Cf. the Barn at Brook, *ibid.*, 6-9.

¹⁸ See section and discussion of the upper chamber more or less completely within the roof-hip in J. T. Smith, 'Medieval aisled Halls . . .', *Arch. J.*, cxii (1955), 76 ff., esp. 84-6 and fig. 3.

¹⁹ G. and S. Colman, 'A thirteenth-century aisled House', *Proc. Suffolk Inst. Arch.*, xxx (1966), 149-65.

FOURTEENTH-CENTURY HALLS IN THE EAST WEALD

necessary to the hall, is separately framed and different in detail, the one complete truss being carried on a post set against the rear inset post of the hall, in the same line (see Fig. 1). In the longitudinal section these appear superimposed.

The Hall (A). This is of one build with the porch (B), of which the inner and outer derno share the same rather shallow ovolo mould that is the only ornament used in this build. Omitting the lost extension, the hall comprises two bays, 16 ft. square in plan, within the inset posts and the notional aisle-posts obviated by the base-crucks, and about 16 ft. high to the ties. The width over the quasi-aisles and central truss and the height to the collar-purlin are 24 ft. Only the front screens door survives (Fig. 2D), but this is framed in broad, but not massive, derno set into a plate, which is a few inches lower than the plate that now carries the rafters, and the pitch of the roof suggests this has always been so, i.e. the wall-plate of the hall was formed by a double girder (see Fig. 2A, B) held apart by blocking pieces and presumably clasping the terminal wall-plate.²⁰ The original clap-boarded door-leaf survives; though rehung it has an enclosing frame and widely-spaced cross-batons behind,²¹ and originally had long strap-hinges. The inner derno has mortices for the usual dwarf spere (Fig. 2D).²² Of the low end partition (Fig. 2B) little can be said at ground-floor level owing to the stack, but the beam above the service doors is chamfered to within 8 in. of the main posts and the spacing of the pegs suggests two, wide, service doors, not three. Above the tie it carries a braced crown-post clasping the collar-purlin. The great arch-braces to the main plates were of the same width as the plates and exactly flush with them, both being square in section, but the posts, though without jowls, were a little wider, and an upstand an inch or so wide is reserved towards the centre of the hall.

The base-cruck blades (Plate IIA, Fig. 2A) were elbowed rather than curved, as at Tickerage and Homewood House, Bolney, and carried small ovoli throughout their length. As in the Sussex examples, it is not clear how the wall-plates were notched or otherwise attached to the shoulders of the crucks. The blades do not support the main plates directly but carry short spur ties, which, in turn carry the plates, and if the spurs had formed a continuous tie, this would have been a case of 'reversed assembly'.²³ But in fact they are cut off by long

²⁰ The theme of parallel and clasping members as a vestigial and recessive feature in timber-framing needs further investigation.

²¹ This form, with three or four narrow cross-batons, seems much commoner in Kent in church-doors of about this period, than, say, the diagonal lattice-frame common elsewhere.

²² Which remained the normal practice in halls, but hardly ever survives.

²³ For this recessive form cf. C. J. Hewett 'Structural Carpentry in Medieval Essex', *Med. Arch.*, vi-vii (1962-63), 240-71

FOURTEENTH-CENTURY HALLS IN THE EAST WEALD

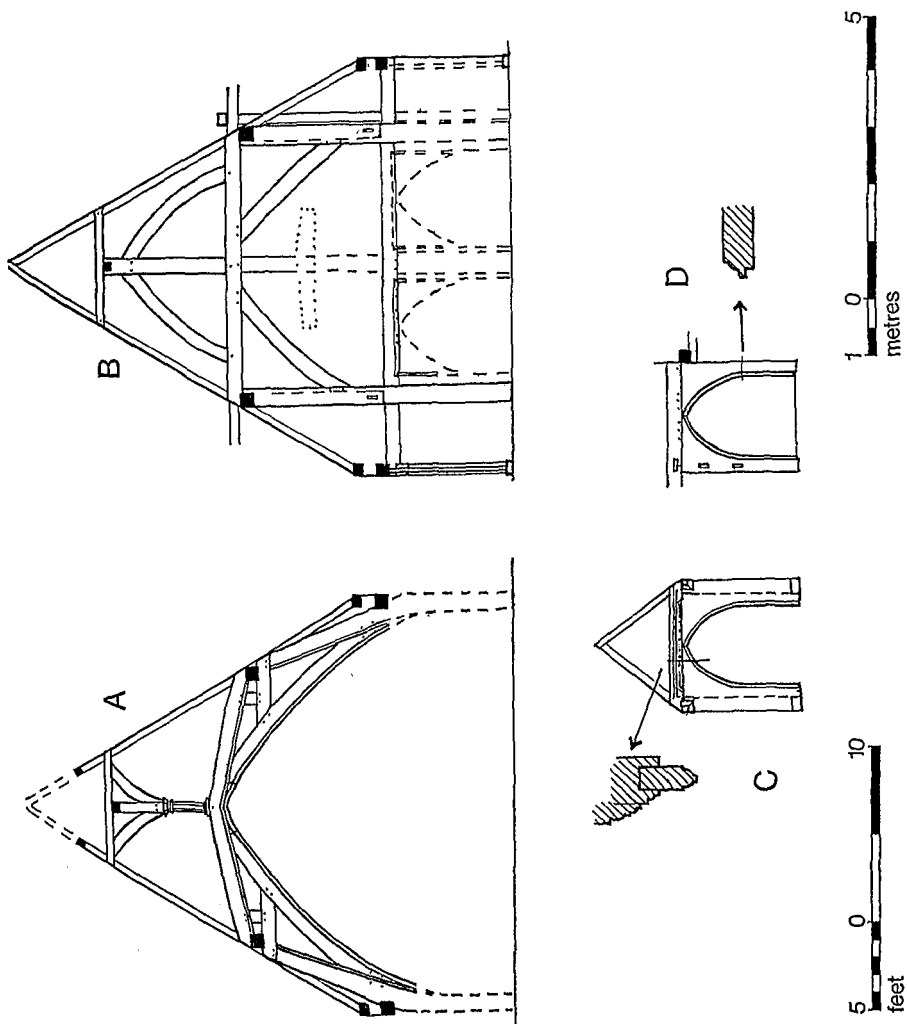

Fig. 2. Hamden.

FOURTEENTH-CENTURY HALLS IN THE EAST WEALD

but delicately curved transverse arch-braces, bearing broader ovoli, rising from the elbow of the blade to a cambered upper tie, riding over the main plates and supported on the spurs by blocking pieces. The main plates could thus be considered as clasped between two ties, as is known in other base-cruck structures.²⁴ There is no wind-bracing in the roof-slope between the plates and the central truss. The upper tie carries a crown-post (Fig. 3A), with neat ovoli on cap, base and necking, and the collar-purlin has a splayed scarf above the post.

Only five rafters are original in the 'high' bay, but in the 'low' bay they are intact and across the three-rafter intervals nearest the truss they are trimmed off 20 in. above the collars by short side-purlins, a clear indication of a louver, as shown on Figs. 1 and 2A.

The method of clasping the plate within the spur-tie, upper tie and blocking piece is precisely paralleled at the approximately contemporary, single-aisled Homewood House, and at the rather earlier, double-aisled, Chennells Brook, Horsham.²⁵ But in neither of these does the whole truss have the grace and assurance of Hamden, reflecting an experience with deep-aisled structures, including barns, that seem peculiarly Kentish.

The Porch (B) now has side-walls of brick, but was originally a separate little framed, gabled structure, of a type now rare in houses²⁶ but rather commoner in churches,²⁷ where it is often, as here, about 9 ft. square. Only the 4-in. thick oak derns (Plate IB, Fig. 2C), set into a lintel, which is in turn set into a tie, remain. All these members bear ovolo mouldings, which run on both faces of the derns, showing they are *not* reused from the rear of hall. Enough remains to show that the lateral plates were, as usually, but not invariably, in church porches, carried by separate corner posts, not by the outer corners of the derns; these plates were doubtless tapered to carry barge-boards.

The original Cross-wing (C), which must follow closely on the hall, is characterized by neat chamfers with slightly reserved stops; the

²⁴ Cf. note 20, p. 250; examples in base-cruck contexts are the hall at Long Crendon, Bucks, and the barns at Middle Littleton, Worcs. (W. Horn and F. W. B. Charles, *Journ. Soc. Archit. Hist.*, xxv (1966), 221-30, and Dorchester, Oxon. (*Arch. J.*, cxv (1958), 127, pl. xvii).

²⁵ R. T. Mason, *Framed Buildings of the Weald*, fig. 4, 22. Though not shown precisely thus in the tentative reconstruction (*Arch. J.*, cxxii (1965), 106), this may also have been the form at Moor Hall, Harefield, Middx., where the blocking piece certainly existed.

²⁶ There is a fine example at the fourteenth-century Middle Farm, Harwell, Berks.: but no others standing in Kent (?)—Joyden's Wood had one (see note 7, p. 247) and something similar existed at Pitstock, Rodmersham, but is not among the (not conspicuously early) parts of this house reassembled at Fox Hill, Sittingbourne.

²⁷ A study of these, widely distributed from East Anglia to eastern Wessex and south-eastwards, is in progress. Ovolo mouldings are very rare, but occur, e.g. at Horsmonden and High Halden, also Shipley, Sussex.

FOURTEENTH-CENTURY HALLS IN THE EAST WEALD

ovolo does not appear. The most recognizable feature is the truss standing beside the rear inset post of the hall and shown in the longitudinal section. The chamfered plates are cut off a little beyond this, and the hipped rear part is rebuilt and its original length uncertain. The chamfer is stopped where the arch-braces enter the nearly square tie-beams and the long-jowled posts, and the simple chamfered crown-post (Fig. 3B) is braced upwards in three directions but not at the rear, though the posts and tie are chamfered on this side also. Above it the light collar is duplicated. The front of the wing has certainly been altered—a similar crown-post has had its base cut off and the tie it stands on spans the plates, but apparently has no supporting posts. It may have been moved, but now stands $15\frac{1}{2}$ ft. from the rear post and some $5\frac{1}{2}$ ft. from the probably jettied front of the original upper chamber, which was perhaps over 40 ft. long if undivided (certainly the front part was 21 ft. long), and 8 ft. high to the tie. The exact juncture of the plate and the, slightly lower, tie of the end truss of the hall is not visible.

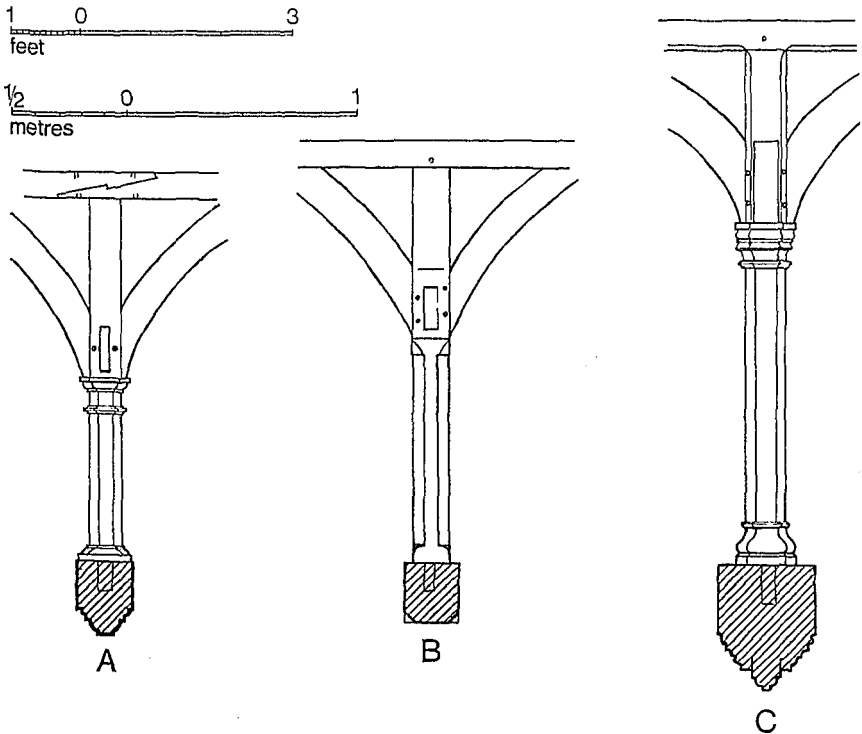

FIG. 3. Crown-posts.

FOURTEENTH-CENTURY HALLS IN THE EAST WEALD

The additional range (D) of the wing had a roof with four trusses, all numbered, but the front one has been moved to make a transverse roof forming the front hip. The principals carry collars without posts and are 'diminished'²⁸ in meaningless and vestigial fashion 6 in. above the collars (see Fig. 1). They have 'alternating' side-purlins²⁹ with common rafters pegged to them. A fine staircase, rising from the passage continuing the line of the rear quasi aisle, to a good filleted door at the head of it, leading to the original upper chamber, and a door-case set in the rear truss of the original wing, with Jacobean-type ovoli, as well as the general form of the added roof, would date all these alterations to the first half of the seventeenth century. The floor in the hall, with a massive transverse beam beside the main base-cruck truss, longitudinal beams flanking the chimney breast, and the joists laid parallel with them would appear to be earlier. At some time lofts were formed at tie-beam level in both hall and wing.

ROOTING (TQ945450)

Rooting, like Hamden, had a cross-wing (W) at the 'low' end, which is all that appears to survive of the medieval house (Plan, Fig. 1). The present, two-storey hall-block, with porch, is brick-cased with typical Surrenden windows, as is the ground floor of the cross-wing; in plan the hall-block may well reflect its predecessor, which the now blocked windows, with neatly chamfered sills, at the sides, of the first floor of the wing (Wo on plan) show to have had much lower side-walls and a steeper roof, and perhaps to have been comparable in form and date to that of Hamden. The wing (Plate IIB, Fig. 4), which is framed independently and presupposes a hall already standing, is demonstrably later; the timbers are very massive for its narrow plan, when compared with the relatively light scantling of everything at Hamden, but the ornamentation, with ovoli predominating, is unusually rich for Kent, where such things as moulded cornices or upper plates are generally an early feature.³⁰ On the other hand, the ogee braces and the bulbous base to the crown-post are more forward looking. A late fourteenth-century date would reconcile these elements.

Of the ground floor of the wing there remain the screens-passage wall with two service doors (Fig. 4C), nearly 5 ft. wide over their ovolo-moulded posts and lintels, enclosing chamfered two-centred arches with plain spandrels, and the partition between the service

²⁸ A characteristic of mature double-framed roofs with clasped side-purlins; cf. J. T. Smith, *op. cit.*, in note 2, p. 246, esp. p. 121.

²⁹ For definition see *Arch. Cant.*, lxxxi (1966), 24.

³⁰ Cf. the porches at High Halden and Wisborough Green, Sussex, both fourteenth century. Where the upper plate of a hall is richly moulded it is generally in association with fourteenth-century type features, e.g. Great Pattenden, Marden.

FOURTEENTH-CENTURY HALLS IN THE EAST WEALD

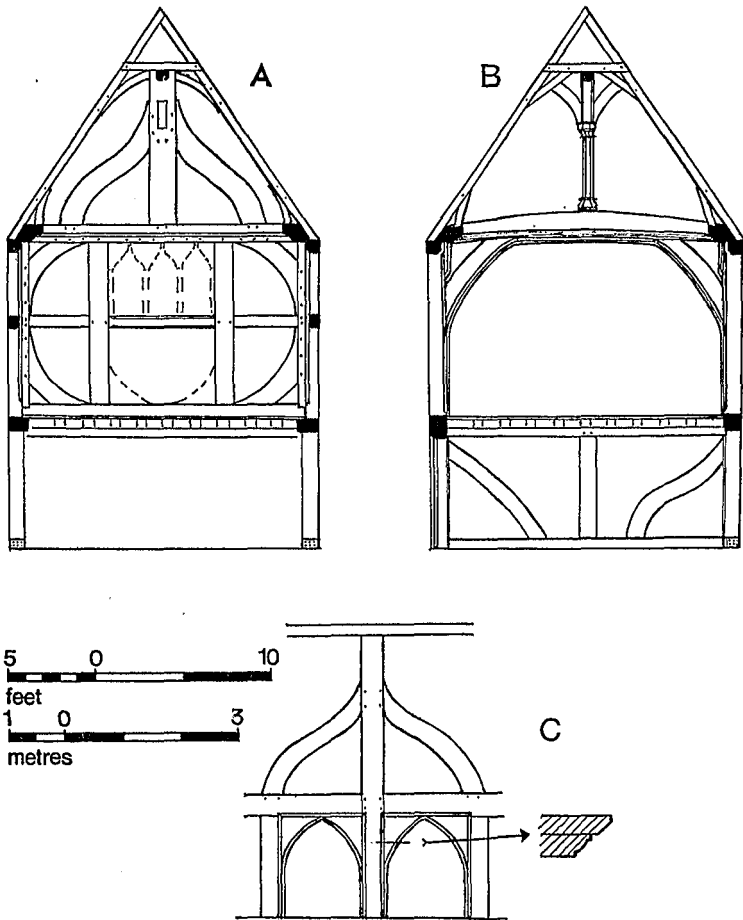

FIG. 4. Roofing.

rooms, with an ogee brace at one end (Fig. 4B). The central post between the service doors carries through to the wall-plate³¹ and has ogee braces at first-floor level.

The upper chamber is not large—two 12½-ft. bays from the jettied and gabled front; the still largely complete frame is elaborately finished (Fig. 4A and B). The hollow chamfered upper plate carries an independent moulded cornice, the plain underside of which projects 6 in. within the plate and is supported on separate, moulded, concave lateral jowls on the jowls of the posts. The cornice moulding running

³¹ A practice almost impossible once the practice of heavily moulding the half-height beams had become established.

FOURTEENTH-CENTURY HALLS IN THE EAST WEALD

round each bay of the chamber and continued along the very broad central tie beam, comprises an ovolo, a cavetto and an ogee (Fig. 3C) and there is a double ovolo on the braces of the tie. The central crown post (Fig. 3C) is tall and massive, with an ogee mould crowning the capital and a relatively squat bulbous base, not far removed from other early instances of this form (e.g. Robertsbridge Abbey and the fourteenth-century hall now at Scadbury, Chislehurst. The upper part of the crown-post is chamfered as is the collar-purlin, and both chamfers are stopped short of their intersection. Each rafter has a canted ashlar bearing on the inset cornice, a refinement more common in ecclesiastical contexts, such as the better finished timber porches.³²

The gable end frame (Plate IIB (exterior), Fig. 4A—envisaged from inside) is an original and rather startling composition based on intersecting circles. The embedded crown-post has broad ogee braces and the terminal pairs of ashlar and braces to the light collars are gently curved to form an elliptical frame for it. The arch-braces or 'knees' of the tie are repeated by curved cheek-pieces at the feet of the side posts, producing a strange, face-like oval framing the central window (now replaced by a brick-mullioned window, set rather lower), and apparently repeated under the window. Such cheek pieces are unusual in any context; they occur as supports to the massive early crown-post at Burstow Lodge, Surrey,³³ but here they seem purely decorative. With the lost ground-floor frame, the whole formed a single curvilinear design, quite unlike the functional pattern of an ordinary braced 'open' frame, but matched in spirit, if not in detail, by certain other bold and decorative wall frames of the fourteenth century—the most astonishing is the tremendous cusped frame in the west wall of Hartley Wespall Church, Hants.³⁴ Perhaps such a design as this launched the persistent fashion for ogee braces so typical of mid Kent.

Kent Archaeological Society is a registered charity number 223382

© Kent Archaeological Society

³² Cf. the plain, chamfered cornices, bearing ashlar, at the porches at Elstead, Surrey, and Little Hallingbury, Essex. They also occurred at Canterbury Guildhall (documented to 1439).

³³ R. T. Mason, *Framed Buildings of the Weald*, pl. xv, D. The practice was widely distributed in the fourteenth century; cf. Wigmore Abbey Gatehouse, Herefordshire (F. H. Crossley, *Timber Building in England*, pl. 5).

³⁴ V.C.H., *Hants*, iv, pl. opp. 42.