

## ST. CUTHBERT'S COTTAGE, BARMING

M. A. OCOCK

### INTRODUCTION

Early in 1975, the Maidstone Area Archaeological Group completed a general survey of the vernacular houses of Barming and the results suggested that St. Cuthbert's Cottage (N.G.R. TQ 72305455) could be one of the earliest of the locality's timber-framed dwellings. No records were known to exist, and it was selected for closer study and survey. The house is currently inhabited, and modern materials and finishes have prevented a complete inspection of the frame. Photographs and drawings have been deposited with the R.C.H.M. National Monuments Record.

The house faces east on to North Street, which, together with South Street, forms a continuous lane running downhill through the village to the River Medway at Barming Bridge. The parish is small, but the village is not nucleated around the church nor anywhere else, and the older houses are widely scattered. St. Cuthbert's Cottage is about 700 m. (765 yds.) north-east of the church, situated higher up the slope but still on lighter soils. In the Tithe Apportionment of 1841, the property is described as 'House, yard and garden', owned and occupied by James Buckland Jnr. The map shows no other roads or footpaths around the property apart from North Street and the name 'St. Cuthbert's Cottage' is not mentioned. Three stages in its development can be identified; a medieval hall-house with a simple collared-rafter roof, a later extension to the rear, also timber-framed, and still later additions, probably of the nineteenth century.

The survey would not have been possible without the permission and active encouragement of the owner, Mrs. P. Bruxner, which was readily forthcoming, and I am indebted to Mrs. H. E. Richardson, for assisting with the survey and the preparation of this paper, to Mr. P. E. Oldham, M.A., for information on the history and development of Barming, and to Mr. S. E. Rigold, M.A., F.S.A., F.R.Hist.S., for reading this report in draft form, making many valuable comments and drawing my attention to Kirkham House.

### DRAWN SURVEY

The main dimensions have been measured between the centre lines of the timbers. Where components of the frame were partly obscured, scantlings have been estimated.

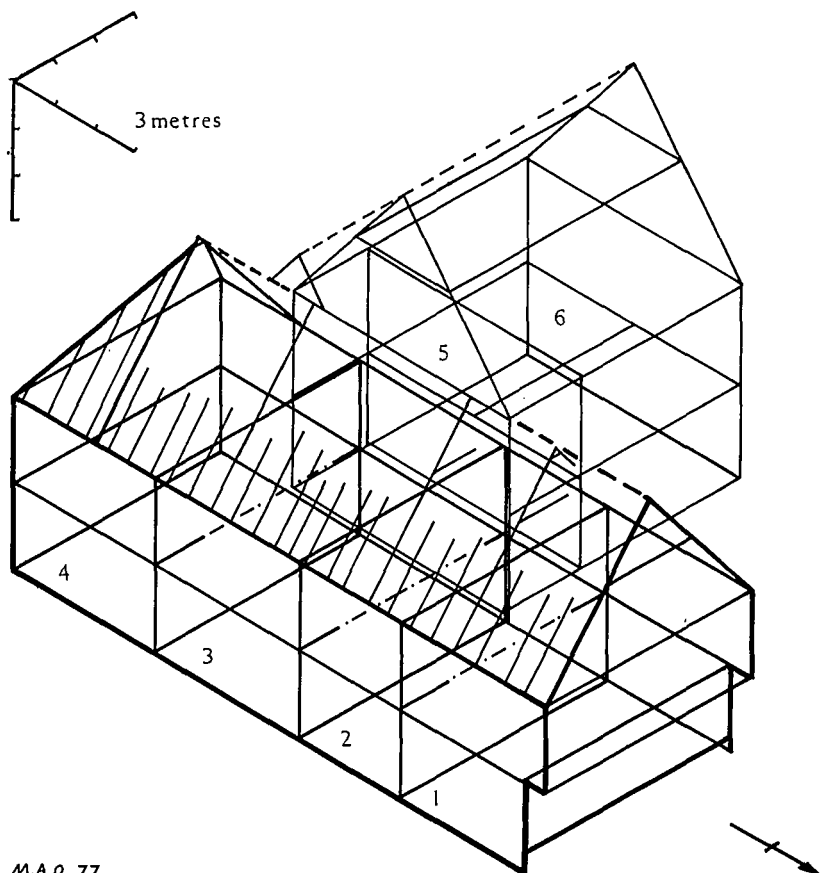

M.A.O. 77

Fig. 1. Isometric Diagram showing the principal Members of the Timber Frame.

*Fig. 1*

The principal members of the medieval house, except rafters, are shown in heavy line. The earliest structure, bays 1-4, diminishes in width from 5.40 m. (17 ft. 8 in.) to 5.05 m. (16 ft. 6 in.). Heights were measured at two locations only, but distances between eaves and sills in both periods appear constant. The sill to bays 5 and 6 is some 13 cm. (5 in.) above that elsewhere, except across the north end of bay 1 where the sill is about 40 cm. (16 in.) higher than on the remaining three sides of the medieval house, apparently to accommodate a sharp rise in the ground due, possibly, to the presence of a lynchet and field boundary.

Although the north end of the present house is gabled, a short collar at high level similar to that found at the southern end, which is hipped, occurs on the fourth pair of rafters from the gable. In Fig. 1, the roof

ST. CUTHBERT'S COTTAGE, BARMING

timbers between bays 5 and 6, the nineteenth-century gabled additions in the north-west angle, and the extension of similar date beyond bay 6, have been omitted. In the medieval house, two of the ten remaining couples of rafters and light collars have been included to illustrate the positioning.

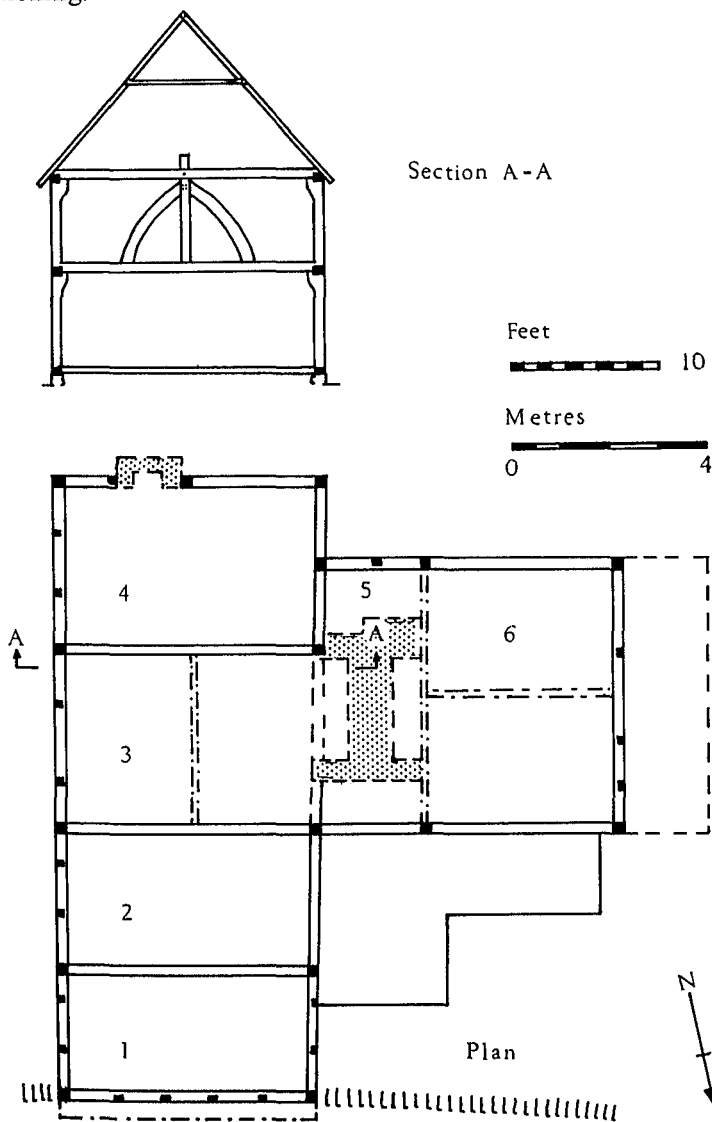

Fig. 2. Plan and Section (looking South) through Bay 3 (A-A).

*Fig. 2*

The nineteenth-century additions are on the plan in outline only; that beyond bay 6 is a first floor structure and is shown with a broken line. Studs and posts are indicated where visible or where their positions can be reasonably inferred. The beam in bay 3 and the chimney stacks in bays 4 and 5 are all later insertions. The abrupt rise in ground level at the north end is shown in line with the end wall to bay 1. On the section the western extensions, bays 5 and 6, are omitted. The transverse down-braces and central post at first floor level are repeated at the north end of the bay.

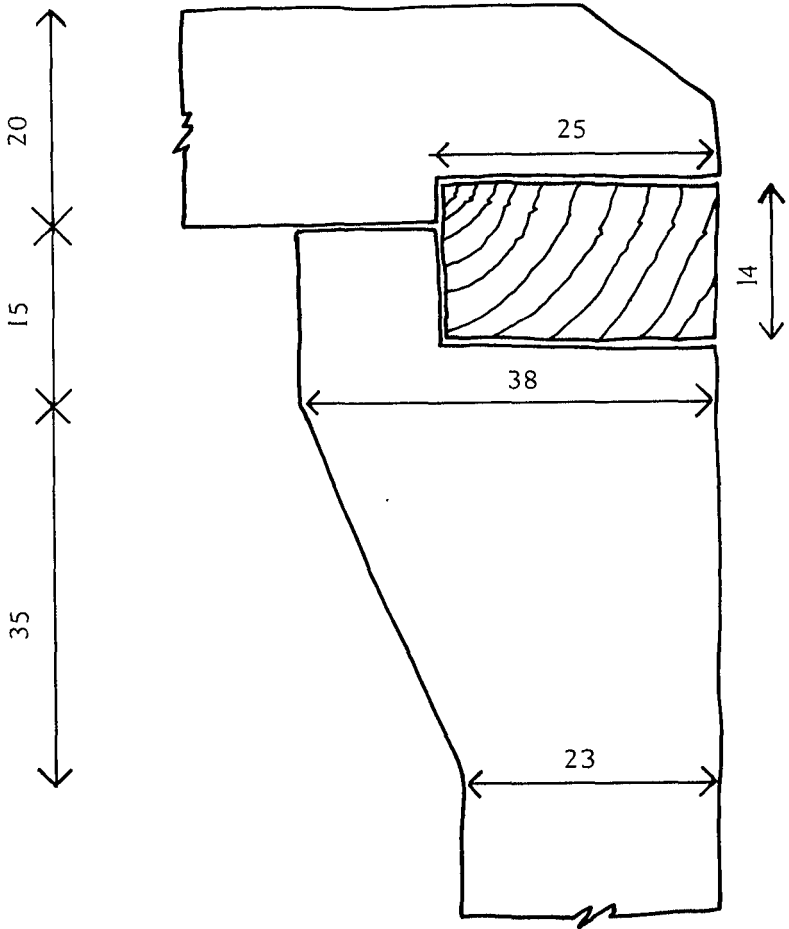

Fig. 3. Detail at typical Post Head. (Dimensions in Centimetres)

*Fig. 3*

This detail occurs consistently at the end of tie beams in bays 1-4. Note the wall-plate 'laid flat' and the short but well shaped jowl. The dimensions given are typical.

## PLATES

Plates IA and IB are from the north-east and north-west respectively; the nineteenth-century additions are identified by their weatherboard cladding. Other photographs, deposited with the National Monuments Record, show both types of roof construction, the position of a medieval window on the west side of bay 2 at first floor level, and the construction illustrated in Fig. 3.

## DESCRIPTION

*Bays 1-4*

Bays 1-4 form a four-bay medieval hall-house, with an end jetty. Smoke-blackened timbers in the roof are confined to the area above bay 3, which has an inserted first floor. The oak frame, which everywhere is carried on a sleeper wall of ragstone about 20 cm. (8 in.) high, is largely hidden by rendering. Visible evidence of bracing is scarce; on either side of bay 3 there are braces to central posts (Fig. 3) and mortises in the partition frame between bays 1 and 2 suggest the former existence of arch braces between tie beam and posts.

The present form of roof structure over the medieval house presents two problems; was the north end at one time hipped and is the absence of crown-posts and a collar purlin the result of later modifications? The north end provides contradictory evidence on the former point, as the fourth pair of rafters from the end has a second smaller collar at high level. This arrangement is necessary for a hip and gablet, which does occur at the opposite end, although there is no evidence of a hip being extended into a gable and the rafters beyond the 'false' gablet are similar in every respect to those in bays 2 and 4. The pair carrying both the smaller and larger collar shows no trace of fixings for jack rafters. The gable is formed of a slender collar to the end rafters with vertical studding above and below. There is, perhaps, less doubt over the roof type. Rafters are of two sizes, 12 cm.  $\times$  8 cm. ( $4\frac{3}{4}$  in.  $\times$  3 in.) over bays 1, 2 and 4, and 15 cm.  $\times$  9 cm. (6 in.  $\times$   $3\frac{1}{2}$  in.) over bay 3, where they, and the collars, are soot-stained. The rafters are halved and pegged at the ridge and the collars (9 cm. square) are lap-jointed to them. Later strengthening has taken place with the insertion of rough side purlins jointed with heavy nails and a simple form of scarf. They are held against the rafters by four crude collars of re-used slightly curved

braces wedged between them. Two of these are heavily coated with soot, and a fifth, also soot-stained, was lying loose on the ceiling joists. Apart from these, the hip rafters at the south end include one soot-stained rafter, and as none are missing from over the hall, it is probable it was imported for repairs. There is nothing to suggest the roof ever had crown-posts or a central collar purlin. Five of the seven collars over bay 3 remain and like their associated rafters all are heavily coated with soot. This coating is continuous on their undersides without the break in the centre which might have indicated the position of a collar purlin. It is evident that the roof is a genuine example of the plain collared-rafter type. At either end of bay 3 the tops of the central posts are halved around and extend beyond the tie; that nearest the south end projects about 40 cm. (16 in.), but in neither case is there any indication that the posts ever continued on to form crown-posts. The upper surfaces of all tie-beams except that between bays 3 and 4, are concealed by ceilings. This has two small rectangular mortices, each positioned about 1 m. on either side of the centre post. They would not fit braces for a crown-post and housing for the feet of two studs would seem a more likely explanation, although the resulting partition would hardly be substantial. An inserted beam with plain chamfers and run-out stops provides support for the first floor in bay 3.

### *Bays 5 and 6*

The later extension to the rear is also framed and, although storey heights are greater, the frame is of inferior construction, with plain timbers and no bracing; at least one tie-beam was cut away at the time of the further additions in the nineteenth century and everywhere plain chamfers are finished with run-out stops. Little of the roof was accessible, but a main truss adjacent to the chimney stack in bay 5 was of the clasped purlin type with an unusually deep collar and without queen-struts. This roof, too, had been subsequently strengthened by the addition of a further pair of side purlins supported by diagonal struts nailed to the face of the collar below. Bay 5 appears to have been designed to accommodate a chimney stack of two hearths on the ground floor only, which is constructed of ragstone at the base and in brick above the level of the first floor. The main hearth serves the earlier building (bay 3) and has an oak lintel forming a shallow four-centred arch. The rear fireplace has a plain lintel and a ragstone surround.

### LATER WORKS AND OUTBUILDINGS

Later works involved infilling the entire frame up to first-floor level with brick noggin and completely covering the remainder with

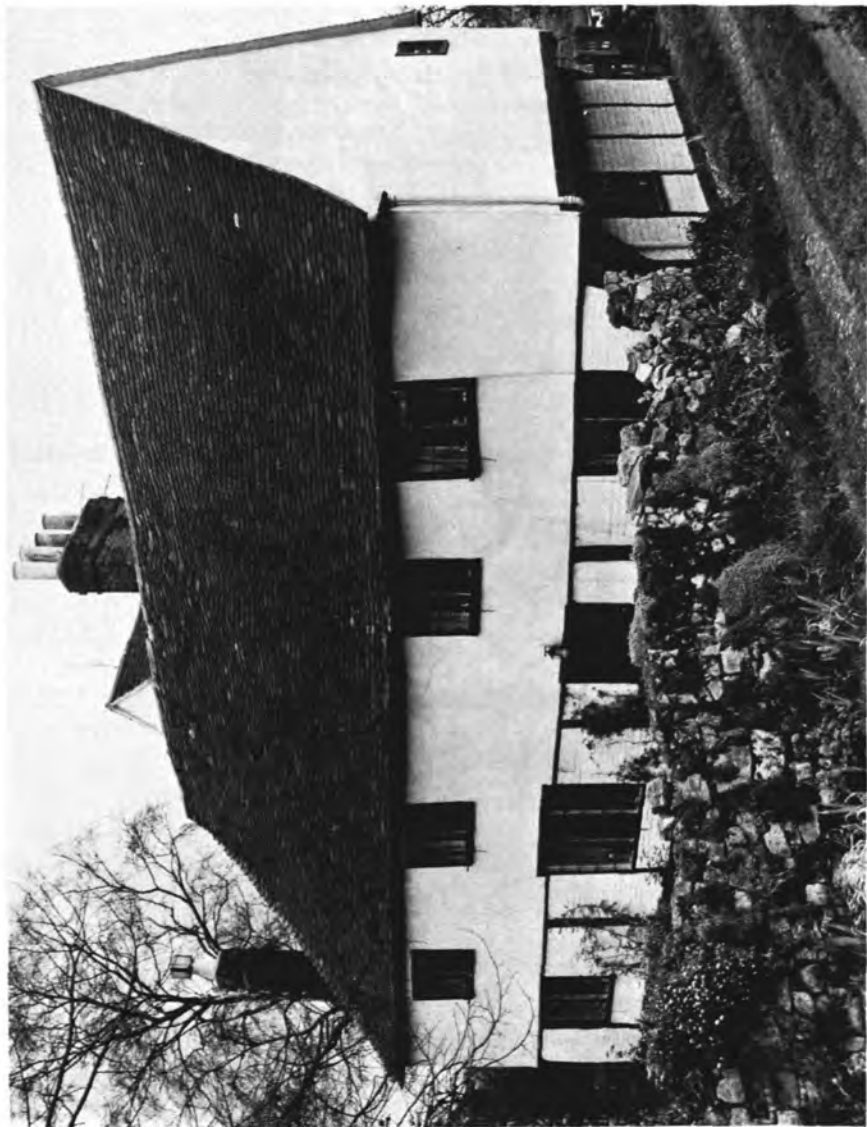

St. Cuthbert's Cottage, from the North-east. *Photo: M. A. Orcock*

Plate 1B

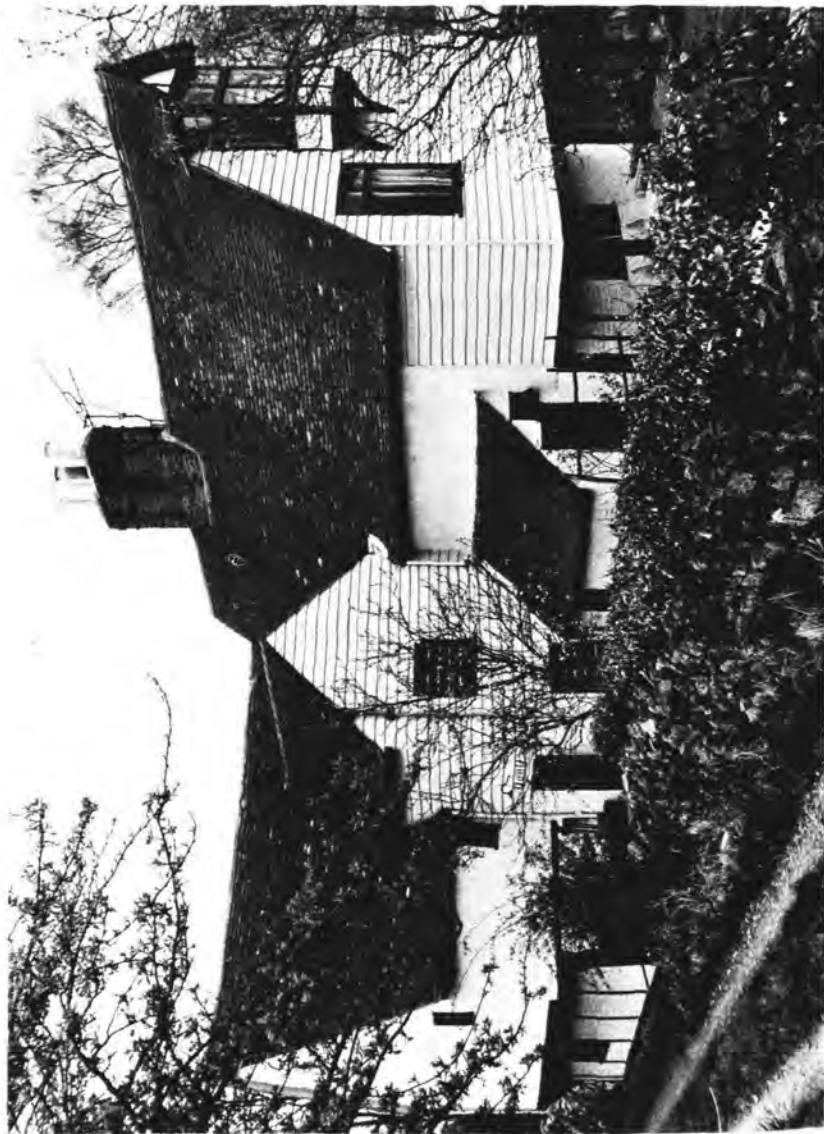

View from the North-west, Photo; M. A. Orcock



## ST. CUTHBERT'S COTTAGE, BARMING

rendering. A staircase has been introduced into the north-west corner of bay 1 and the close vertical studding, visible internally in that position, is of a late date, but mortices for the original studding remain. Opposite the north end of the house is an outbuilding with ragstone walls and a timber roof similar in construction to the main extension at the rear of the house (bays 5 and 6). A few of the rafters in various parts of the roof are soot-stained with medieval features and are obviously imported as none are missing from over the hall.

### ANALYSIS

Externally, the main and earliest part of the building has every appearance of an end-jettied four-bay medieval hall-house, having the usual plan with a two-bay central hall. However, the interior suggests otherwise. Soot-encrusted rafters and an inserted first floor confirm that bay 3 formed probably the entire hall, at least at first-floor level. It was impossible to determine whether at ground level the hall originally included bay 2, and if so, whether the consequentially overhung first floor was primary or an insertion. The existence of a larger size of rafter over this bay might be considered as resulting from a substantial reconstruction of the roof, although in the absence of other evidence this seems unlikely; neither is there anything to suggest that at the north end the present gable results from the conversion of a former hip. Other parts of the frame show clearly that the four bays were erected as one structure. It has already been demonstrated that it almost certainly had no crown-posts and, until the later insertion of side purlins, the roof consisted entirely of rafters and collars. This roof type, though simple, persisted for a considerable time<sup>1</sup> and indications of date must come from recognizable features elsewhere, such as the end jetty, the simple, though certainly not crude, style of construction and the short stubby jowls at the top of the main posts, which together suggest a well constructed dwelling of a fourteenth-century date rather than a house low in the social scale and of a later period. A later date could be supported by the existence of a hall restricted, at least at the upper floor level, to one bay, but this does not accord with other features. It is likely that bay 1 contained services and served in part as a workshop, with bay 2 either as part of the hall at ground level or, less likely, as an extension to the primary service bay. Whatever the exact form of this hall, the square single-bay hall is

<sup>1</sup>J. T. Smith, 'The Reliability of typological Dating of Medieval English Roofs', in, R. Berger (Ed.), *Scientific Methods in medieval Archaeology*, Los Angeles and London, 1970, 249.

certainly known in an early context,<sup>2</sup> and an example of a late-fourteenth-century house, with an upper chamber projecting over the hall, as may have been the case here, can be seen at Kirkham House, Paignton, Devon. The half-height beam remains hidden behind plaster and likewise there is an absence of visible chamfers, but straight tie beams without a camber lend support to the earlier dating, and Mr. S. E. Rigold has suggested that the date of the medieval hall-house is comfortably back in the fourteenth century.

A rear extension to bay 3, overlapping bay 4, provided the opportunity to install a lateral fireplace for the hall rather than one in the usual position across the open hall (here inconveniently small) as well as, in the same stack, a kitchen hearth. It is likely that at the same time the hall was floored over. Dating of this extension which contains the staircase is less secure, but the first half of the seventeenth century would not seem out of place; beams of an earlier date might be expected to exhibit more elaborate characteristics and be closer to other mid-Kent examples of the same vernacular level.

Kent Archaeological Society is a registered charity number 223382

© Kent Archaeological Society 11th August 2014

<sup>2</sup>Kentish examples include The Old Manor House, Bearsted (unpublished) and a moated house at Pivington (S. E. Rigold, 'Excavation of a moated Site at Pivington', *Arch. Cant.*, lxxvii (1962), 27-47).